

HIGH PRODUCTIVITY • ROBUSTNESS • PRECISION • TECHNOLOGY

CNC LATHES

# ROMI C SERIES

NEW GENERATION



[www.romi.com](http://www.romi.com)







MUCH MORE  
PRODUCTIVITY  
AND PROFITABILITY  
FOR YOUR  
BUSINESS!

*In the constant transformation of industrial processes, it is crucial to have **competitive advantages that make your products superior.***

*In this context, the integration of new technologies into your production process, particularly through **modern, fast, and precise machine tools, enhances production performance.***

*You achieve higher quality, productivity, efficiency, and, most importantly, higher profits than what you have already achieved in your business!*

With more than 90 years of history and global presence, we have preserved the values that have made our products recognized worldwide. **We offer the most cost-effective machine tools on the market.** Our commitment to the constant development of new solutions and dedication to innovation, results in robust, highly technological and quality machine tools.

**We guarantee full support at all stages of purchase** through our sales and sales engineering teams, customer training, specialized technical assistance and spare parts.

**Owning a Romi machine tool assures that you have state of the art equipment** combined with a reputation of value, providing a high resale value in the future.

At Romi, you get a complete solution, much more than just a piece of equipment: **you have the security and confidence of counting on the manufacturer at all times, whenever you need it.** Count on us to find a solution that fits your needs. **Our main goal is to make your business even more productive and profitable.**



Ultra Clean room



R & D



Flexible Manufacturing System (FMS)



Specialized technical assistance

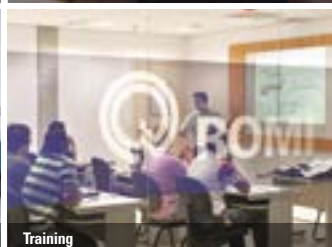

Training



Spare parts

# ROMI C SERIES

NEW GENERATION

Flexibility and high productivity for various types of machining





The CNC Lathes from the **ROMI C Series - New Generation** offer great versatility for machining different types of parts, with excellent levels of power, speed of movement, and machining precision. With a robust structure, high rigidity, and stability, they provide excellent performance under various machining conditions.



### ROMI C470

<b>Headstock</b>	A2-5" - 4,000 rpm A2-6" - 3,000 rpm
<b>Main motor</b>	12.5 hp / 9 kW
<b>CNC</b>	CNC Siemens Sinumerik 828D



### ROMI C570

<b>Headstock</b>	A2-6" - 3,000 rpm A2-8" - 2,200 rpm
<b>Main motor</b>	15 hp / 11 kW
<b>CNC</b>	CNC Siemens Sinumerik 828D



### ROMI C670

<b>Headstock</b>	A2-8" - 1,800 rpm
<b>Main motor</b>	24.7 hp / 18.2 kW
<b>CNC</b>	CNC Siemens Sinumerik 828D





# STRUCTURE

## ROBUSTNESS AND TECHNOLOGY

The lathes from the ROMI C Series - New Generation have a robust structure bed supported by cast iron columns with internal ribbing to absorb vibrations during various machining conditions.

The flat and prismatic guides, induction-hardened and ground, ensure high durability and form a self-adjusting system, guaranteeing constant contact between the table and the bed.

These features provide machine rigidity, stability, and precision during full-power operations.

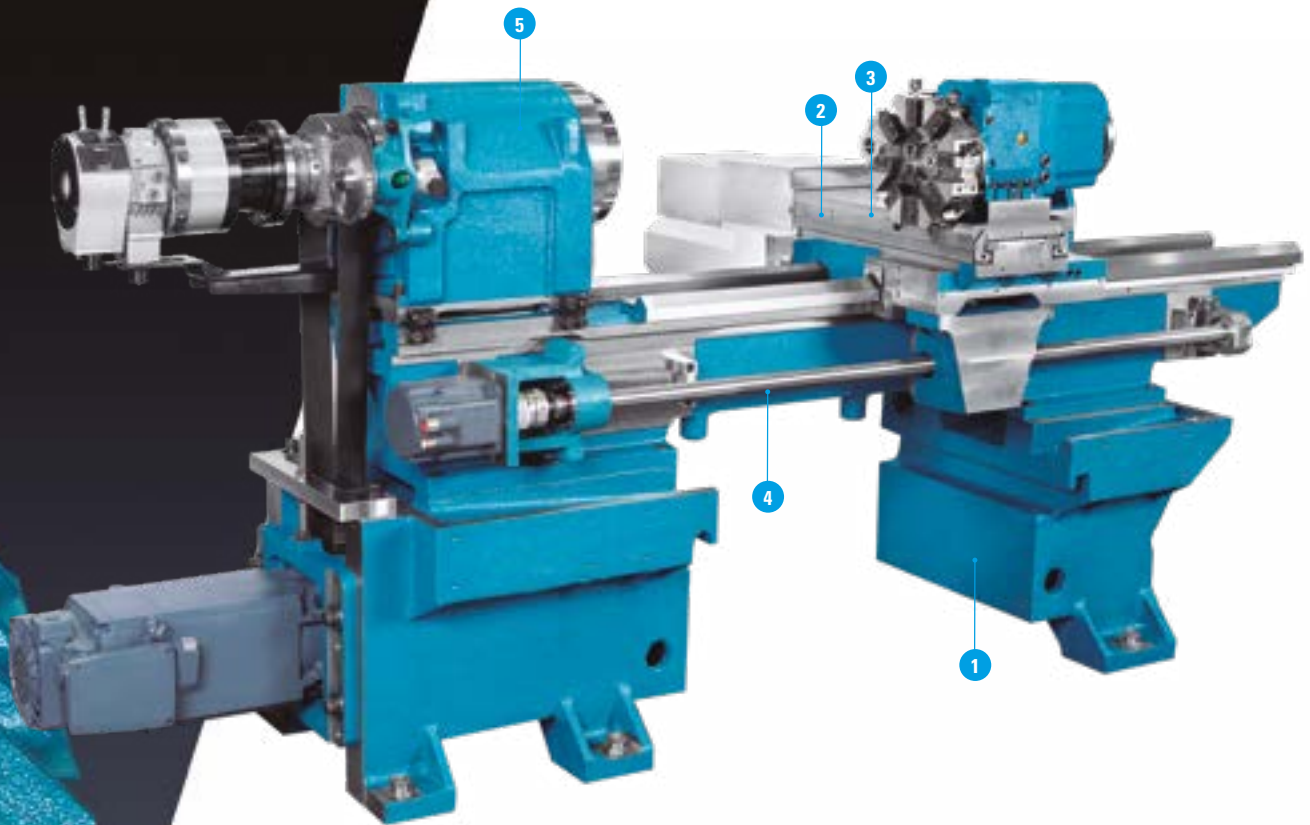

**1** Ribbed cast iron bed supported by columns, forming a unit that guarantees rigidity and dimensional stability to the machine, supporting its main assemblies.

**2** Cross slide supported by steel **box ways guides, induction-hardened and ground**, with application of "TURCITE," allowing for high accelerations and speeds, forming a highly rigid assembly with excellent geometric precision.

**3** Longitudinal (Z-axis) and transverse (X-axis) rapid feeds of 10,000 mm/min (393.7 in/min) for C 470 and C 570, and 8,000 mm/min (314.96 in/min) for C670.

**4** Precision "X" and "Z" axis ball screws, hardened and ground, mounted on angular contact bearings and **directly coupled** to the servo motors.

**5** Cartridge-type spindle head mounted on precision bearings with high load capacity, offering rigidity and excellent vibration absorption under the most severe cutting conditions, allowing for machining with excellent geometric precision. It is driven by an AC motor through pulleys and a micro "V" belt, with forced air cooling.



# HEADSTOCK

## C 470, C 570, and C 670

The robust structure of the headstock that incorporates the cartridge has a spindle supported by precision bearings with high load capacity, offering rigidity and great vibration absorption under the most severe cutting conditions, allowing for machining with excellent geometric precision. It is driven by an AC motor through pulleys and a micro-V belt, which provides high torque and continuous speed variation.







## ▲ CHUCKS

The CNC Lathes from the ROMI C Series - New Generation can be configured with various types of chucks (\*):

- Universal 3-jaw chuck
- Hydraulic 3-jaw chuck
- Independent 4-jaw chuck

(\*): mandatory optional choices, availability according to the machine model.

## Tool holders and turrets (optional)\*

- Gang tools holder (C 470)
- Rear tool holder (C 470/570/670)
- Quick-change tool holder 2 or 3 faces (C 470)
- Square manual turret (C 470)
- Quick-change tool holder 3 faces (C 570/670)
- Horizontal 8-position electric turret (C470 [std.] / C 570/670 [opt])
- Vertical 4-position electric turret Duplomatic (C 670)
- Horizontal 8-position electric turret with driven tool Sauter (C 670)



◀ Electric turret with 8 positions of horizontal axis (optional)

Gang tools (optional) ▶

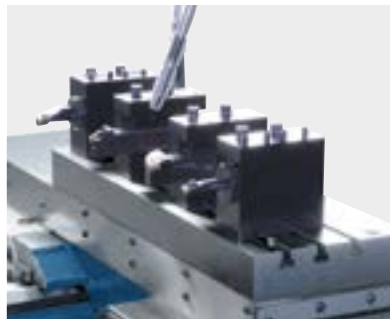

◀ Quick-change tool holder (optional)

\* Availability according to the machine model.





# TOOL TURRETS

HIGH PERFORMANCE AND PRECISION

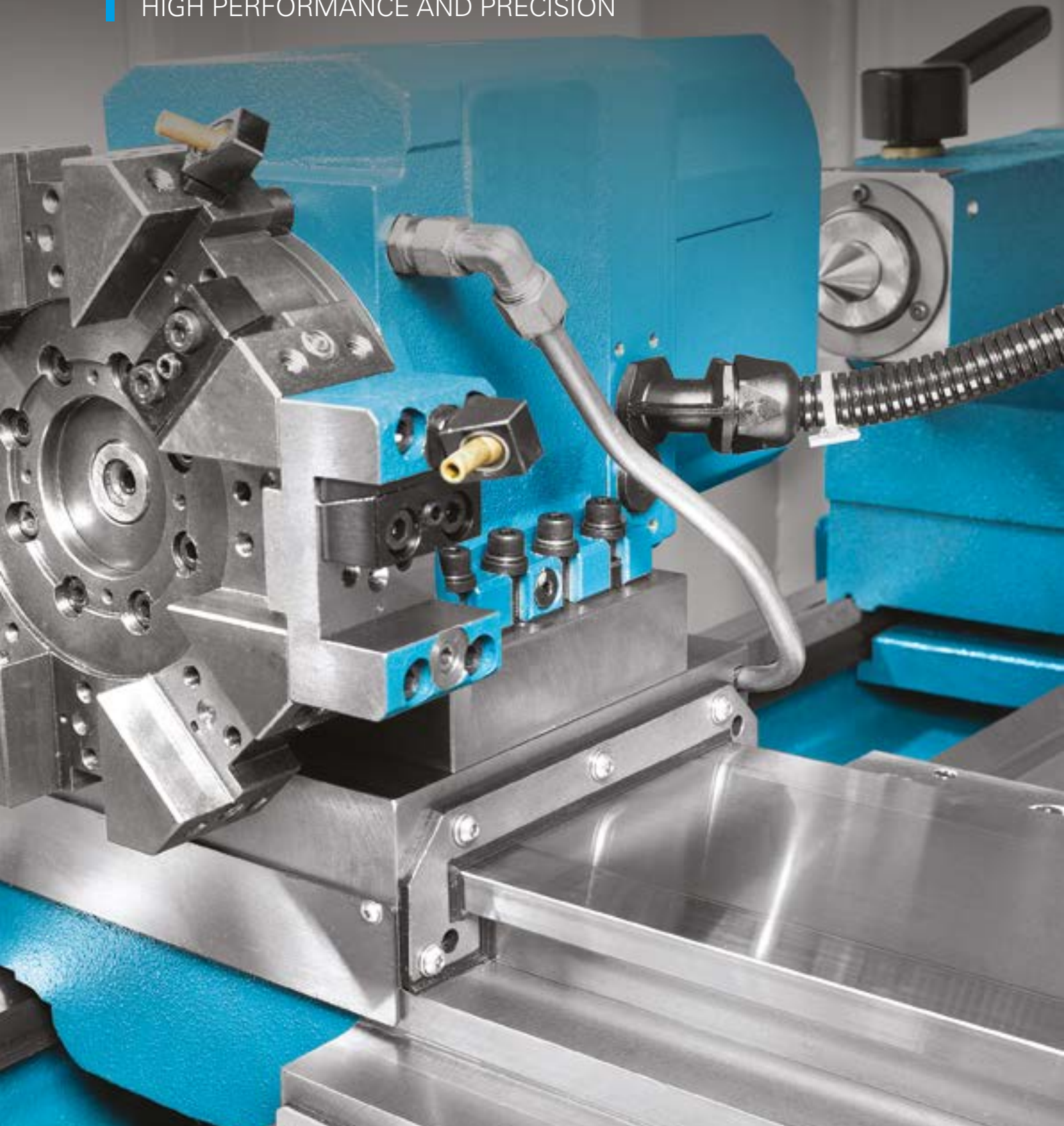



# TAILSTOCK

The ROMI C Series - New Generation is equipped with a manually operated tailstock (standard).

They are positioned manually (standard) or through a drag device on the table (optional).

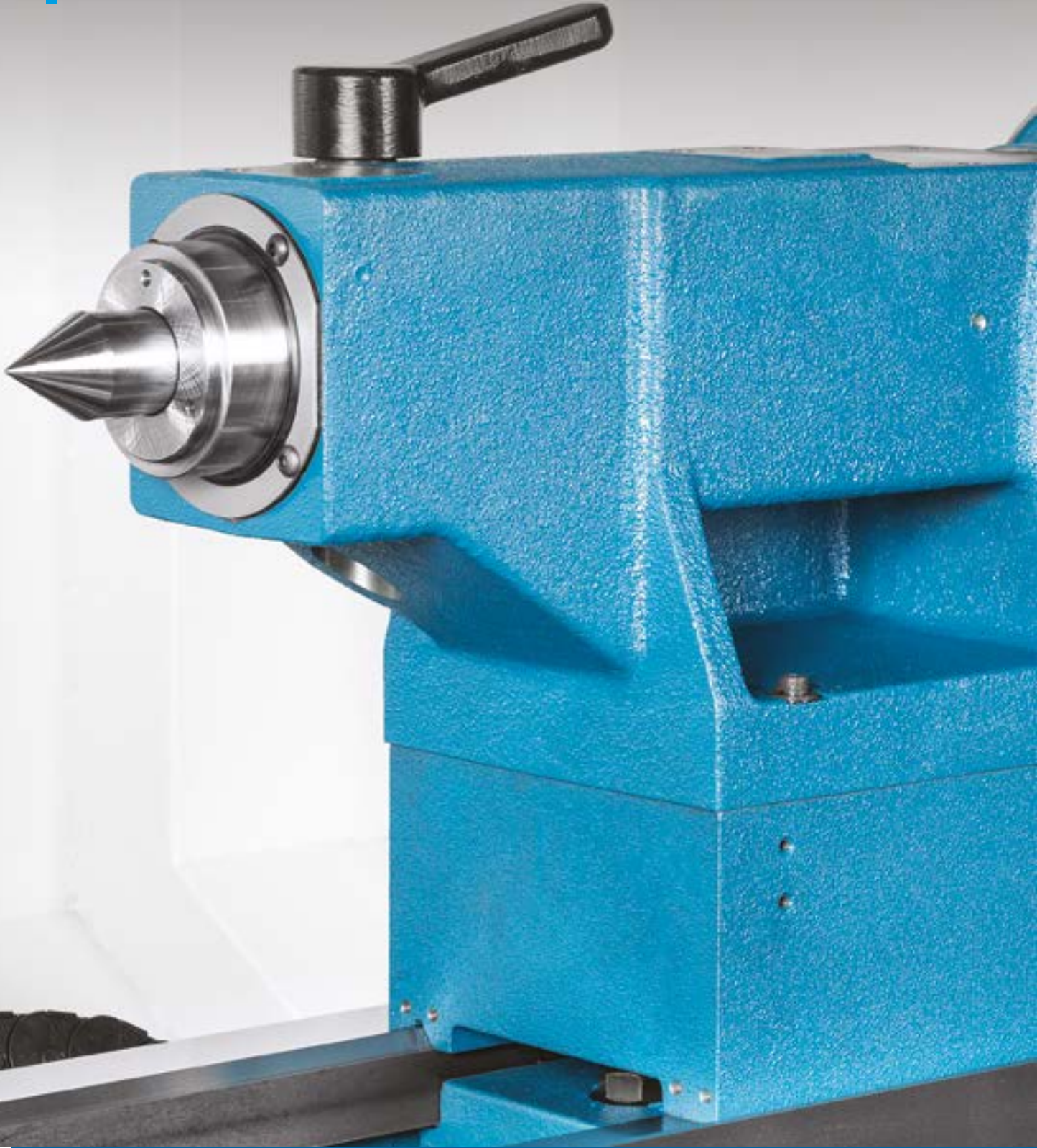





◀ Manual tailstock (standard)



◀ Hydraulic tailstock (optional)

## STEADY REST

To support long workpieces such as shafts, tubes, etc., the ROMI C Series - New Generation lathes can be equipped with different types of steady rests (optional), ensuring perfect support for the machined parts.



▲ **Open fixed steady rest**  
(C 470/570)



▲ **Closed fixed steady rest**  
(C 470/570/670)



▲ **Follow rest**  
(C 470/570)

# CNC

## TECHNOLOGY, PERFORMANCE, AND RELIABILITY

### CNC Siemens Sinumerik 828D

Explore the epitome of innovation – a 15" color LCD touchscreen, English language interface, and versatile communication interfaces including USB and Ethernet. Experience seamless program loading and parameter control for unparalleled productivity and precision. Elevate your operations with cutting-edge technology that defines the future.

It offers excellent resources for creating and editing machining programs, such as canned cycles for turning and drilling, linear and circular interpolation functions, threading functions, reference functions, coordinate systems, 256 pairs of tool correctors, tool life manager, 3 Mbytes of memory, background editing, and excellent resources for 3D machining simulation. Additionally, it provides the conversational ProgramGuide system, which allows for easy and fast generation of machining programs using graphical resources, without the need for ISO codes.



# RMMP

## Romi Manual Machine Package

The RMMP allows operating the machine in manual mode using electronic handwheels and in automatic mode (joystick and cycle start).

The operator can machine parts like on a manual lathe using the electronic handwheels and the control panel joystick.

They can also fill in the fields on the CNC screen, entering speed, feed, cutting depth, coordinates, and angles, and perform machining by pressing the cycle start button.







Technical specifications		C 470		C 570		C 670
<b>Capacity</b>						
Centers height	mm (in)	240 (9.45)		290 (11.42)		340 (13.38)
Distance between centers	mm (in)	1,000 (39.37)		1,500 (59.05)		2,000 (78.74)
Swing over bed	mm (in)	470 (18.50)		570 (22.44)		670 (26.38)
Swing over cross slide	mm (in)	200 (7.87)		255 (10.04)		345 (13.54)
Swing over saddle wings	mm (in)	430 (16.93)		510 (20)		600 (23.6)
Cross slide travel (X axis)	mm (in)	220 (8.66)		280 (11.02)		360 (14.17)
Longitudinal carriage travel (Z axis)	mm (in)	1,065 (41.93)		1,555 (61.22)		2,025 (79.72)
<b>Bed</b>						
Width	mm (in)	305 (12)		380 (14.96)		380 (14.96)
Height	mm (in)	290 (11.42)		290 (11.42)		290 (11.42)
<b>Headstock</b>						
Spindle nose	ASA	A2-5"	A2-6"	A2-6"	A2-8"	A2-8"
Spindle hole diameter	mm (in)	53 (2.08)	65 (2.56)	65 (2.56)	80 (3.15)	104 (4.09)
Transmission System		Direct drive		Direct drive		Direct drive
Speed Ranges	rpm	4 to 4,000	3 to 3,000	3 to 3,000	2 to 2,200	1 to 1,800
<b>Feeds</b>						
Rapid traverse (Z axis)	m/min (in/min)	10 (0.394)		10 (0.394)		8 (0.314)
Rapid traverse (X axis)	m/min (in/min)	10 (0.394)		10 (0.394)		8 (0.314)
<b>Manual Tailstock</b>						
Body positioning		Manual (std) / Drag through the table (opt)		Manual (std) / Drag through the table (opt)		Drag trough thetable
Quill drive		Manual (std) / Hydraulic (opt)		Manual (std) / Hydraulic (opt)		Manual (std) / Hydraulic (opt)
Maximum quill stroke	mm (in)	120 (4.72)		130 (5.12)		180 (7.08)
Quill diameter	mm (in)	60 (2.36)		80 (3.15)		100 (3.94)
Quill taper hole	CM	4		4		5
<b>Installed power</b>						
AC Main motor (regime S6 - 40%)	hp/kW	12,5 / 9		15 / 11		24,7 / 18,2
Total installed power	kVA	20		20		25
<b>Dimensions and weight (*)</b>						
Floor space required	m (in)	2.91 (114.5) x 1.24 (48.82)		3.65 (143.7) x 1.49 (58.66)		4.84 (190.5) x 1.57 (61.81)
Approx. net weight - 1.0 m between centers	kg (lbs)	2,600 (5,732)		3,550 (7,826)		4,300 (9,480)



Technical specifications			C 470	C 570	C 670
<b>Quick change tool holder (opt)</b>					
Holders			2 or 3	3	3
Tool holder size	Square	mm (in)	25 x 25 (0.98 x 0.98)	25 x 25 (0.98 x 0.98)	25 x 25 (0.98 x 0.98)
	Round	mm (in)	Ø 25 (Ø 0.98)	Ø 25 (Ø 0.98)	Ø 32 (Ø 1.26)
<b>Rear tool holder (opt)</b>					
Tool holder size	Square	mm (in)	20 x 20 (0.79 x 0.79)	25 x 25 (0.98 x 0.98)	25 x 25 (0.98 x 0.98)
	Round	mm (in)	Ø 25 (Ø 0.98)	Ø 32 (Ø 1.26)	Ø 40 (Ø 1.57)
<b>Gang tools (opt)</b>					
Tool holder size	Square	mm (in)	20 x 20 (0.79 x 0.79)	-	-
	Round	mm (in)	Ø 25 (Ø 0.98)	-	-
<b>WTO tool holder (opt)</b>					
Tool holder size	Square	mm (in)	25 x 25 (0.98 x 0.98)	25 x 25 (0.98 x 0.98)	25 x 25 (0.98 x 0.98)
	Round	mm (in)	Ø 25 (Ø 0.98)	Ø 25 (Ø 0.98)	Ø 40 (Ø 1.57)
<b>8-station manual square turret (opt)</b>					
Tool holder size	Square	mm (in)	25 x 25 (0.98 x 0.98)	-	-
	Round	mm (in)	Ø 25 (Ø 0.98)	-	-
<b>4-station square manual tool holder (opt)</b>					
Number of stations / tools		un	-	-	4
Tool holder size	Square	mm (in)	-	-	25 x 25 (0.98 x 0.98)
	Round	mm (in)	-	-	Ø 40 (Ø 1.57)
<b>8-station horizontal automatic turret (opt)</b>					
Tool holder fixing type			ROMI	ROMI or VDI-30	ROMI or VDI-40
Number of stations / tools		un	8	8	8
Tool holder size	Square	mm (in)	25 x 25 (0.98 x 0.98)	25 x 25 (0.98 x 0.98)	25 x 25 (0.98 x 0.98)
	Round	mm (in)	Ø 25 (Ø 0.98)	Ø 32 (Ø 1.26)	Ø 40 (Ø 1.57)
<b>8-station horizontal automatic turret for driven tools (opt)</b>					
Tool holder fixing type			-	-	Disco VDI - 40
Number of stations / tools		un	-	-	8
Tool holder size	Square	mm (in)	-	-	25 x 25 (0.98 x 0.98)
	Round	mm (in)	-	-	Ø 40 (Ø 1.57)
Axial driven tool holder		DIN 6499	-	-	ER - 32 (Ø 3 to Ø 20 mm)
Driven tool speed range		rpm	-	-	3 to 3,400

## Capabilities - dimensions in mm (in)

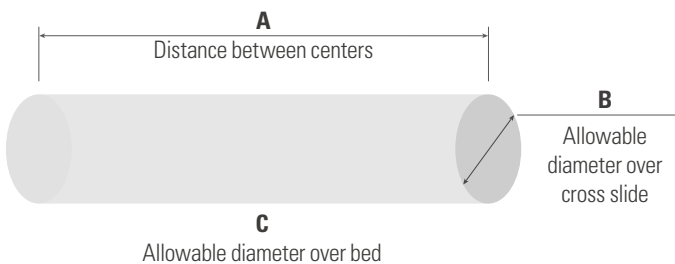

	A	B	C
<b>ROMI C 470</b>	1,000 mm (39.37 in)	Ø 200 mm (7.87 in)	Ø 470 mm (18.5 in)
<b>ROMI C 570</b>	1,500 mm (59.05 in)	Ø 255 mm (10.03 in)	Ø 570 mm (22.44 in)
<b>ROMI C 670</b>	2,000 mm (78.74 in)	Ø 345 mm (13.58 in)	Ø 670 mm (26.38 in)



## Power Graphs

### ROMI C 470

ASA A2-5" Headstock – 4,000 rpm

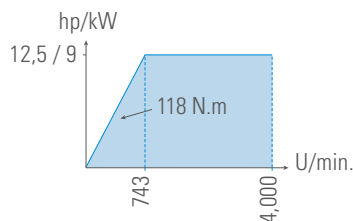

ASA A2-6" Headstock – 3,000 rpm

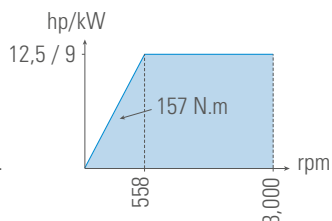

### ROMI C 570

ASA A2-6" Headstock – 3,000 rpm

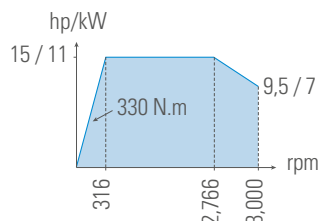

ASA A2-8" Headstock – 2,200 rpm

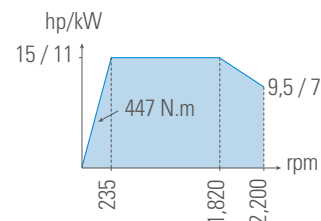

### ROMI C 670

ASA A2-8" Headstock – 1,800 rpm

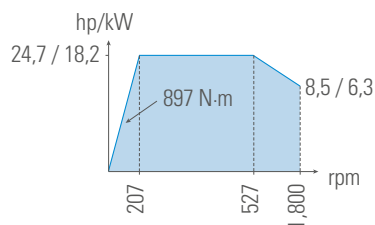

■ Intermittent regime S6-40%

## Machine Dimensions - dimensions in mm

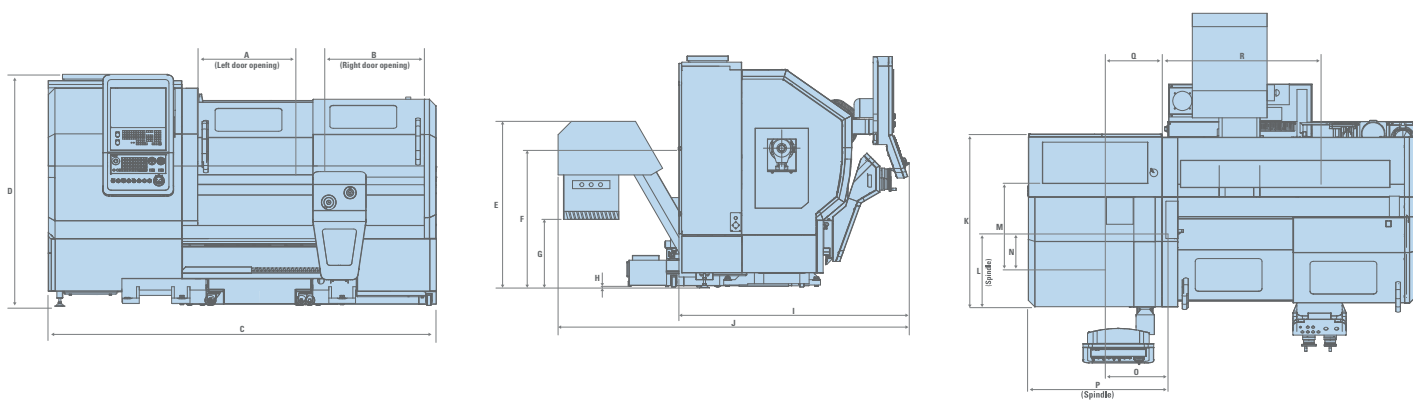

		A	B	C	C1	C2	D	E	F	G	H	I	J	K	L	M	N	O	P	Q	R
<b>ROMI C 470</b>	mm (in)	760 (29.92)	745 (29.33)	2,907 (114.45)	-	-	1,737 (68.38)	1,248 (49.13)	1,046 (41.18)	513 (20.19)	17.5 (0.69)	1,726 (67.95)	2,632 (103.62)	1,293 (50.90)	524 (20.63)	665 (26.18)	260 (10.24)	490 (19.29)	1,082 (42.60)	410 (16.14)	1,200 (47.24)
<b>ROMI C 570</b>	mm (in)	1,485 (58.46)	1,520 (59.82)	3,645 (143.50)	-	-	1,736 (68.35)	1,500 (59.05)	1,288 (50.71)	765 (30.12)	20 (0.78)	1,935 (76.18)	2,880 (113.38)	1,490 (58.66)	654 (25.75)	-	-	-	-	-	-
<b>ROMI C 670</b>	mm (in)	2,000 (78.74)	2,005 (78.94)	4,833 (190.27)	5,145 (202.56)	5,690 (224.01)	1,736 (68.34)	1,824 (71.81)	1,613 (63.50)	1,090 (42.91)	20 (0.78)	2,010 (79.13)	2,205 (86.81)	1,570 (61.81)	760 (29.92)	-	-	-	-	-	-

C1 - Width up to the tank

C2 - Width up to the chip conveyor

Note: C 470 and C570 equipped with cross chip conveyor (optional) and C 670 equipped with longitudinal chip conveyor (optional)



## Standard Equipment

- Headstock with cartridge available in the following versions, according to the machine configuration:
  - ASA A2-5" Spindle, with Ø53mm (Ø2.09") bore, with speed range from 4 to 4,000 rpm **(C 470)**
  - ASA A2-6" Spindle, with Ø65mm (Ø2.56") bore, with speed range from 3 to 3,000 rpm **(C 470 and 570)**
  - ASA A2-8" Spindle, with Ø80mm (Ø3.15") bore, with speed range from 2 to 2,200 rpm **(C 570)**
  - ASA A2-8" Spindle, with Ø104mm (Ø4.09") bore, with speed range from 1 to 1,800 rpm or 2 to 2,500 rpm **(C 670)**
- Manually operated movable tailstock with manual operation of the sleeve (with dry tip)
  - Siemens Sinumerik 828D PPU 290.4 (SW PPU 24X - CF Card) CNC control with 15" LED touchscreen monitor
  - Complete coverage against chips and splashes, including coverage over the movable headstock and electric safety lock
  - Set of leveling screws and nuts
  - Set of main keys for machine operation
  - Complete ROMI product documentation in electronic media
  - LED lamp
  - Electronic handwheel (for machines without "KitMultiplic " accessory)
- Electrical panel with centrifugal climate control and positive pressure
- Standard paint: Textured Epoxy Enamel in Munsell Blue 10B-3/4 and Textured Epoxy Enamel in Gray RAL 7035
- Centralized automatic lubrication system with line filter and oil level sensor
- Coolant system with reservoir and coolant pump
- 8-position horizontal electric turret (size 63), with ROMI standard disk, section 25 x 25 mm, with 1 (one) facing support section 25 x 25 mm, 2 (two) internal supports Ø 25 mm, 5 (five) reduction bushes Ø 8, 10, 12, 16, and 20 mm, and 1 (one) CM-1 bushing **(C 470)**

## Optional Equipment

- Longitudinal metal hinged belt chip conveyor (TCE) - suitable for short spiral chips, usually steel. Available with 1000mm between centers **(C 470)**, 1500mm between centers **(C 570)**, and 2000mm between centers **(C 670)**
- Chip tray. Available with 1000mm between centers **(C 470)**, 1500mm between centers **(C 570)**, and 2000mm between centers **(C 670)**
- Coolant pump (10 lpm @ 5 bar, 1.5 kW / 2 hp)
- Coolant pump (10 lpm @ 7 bar, 1.5 kW / 2 hp)
- Hydraulic chuck Ø 165 mm or Ø 210 mm, serrated 1.5 x 60 mm - A2-5" **(C 470)**
- Hydraulic chuck Ø 210 mm, serrated 1.5 x 60 mm - A2-6" **(C 470)**
- Universal 3-jaw chuck Ø 160 mm or Ø 200 mm, with solid or reversible jaws (overlapping) - A2-5" **(C 470)**
- Universal 3-jaw chuck Ø 200 mm, with solid or reversible jaws (overlapping) - A2-6" **(C 470)**
- Hydraulic chuck Ø 210 mm or Ø 250 mm, serrated 1.5 x 60 mm - A2-6" **(C 570)**
- Hydraulic chuck Ø 250 mm, serrated 1.5 x 60 mm - A2-8" **(C 570)**
- Universal 3-jaw chuck Ø 200 mm or Ø 250 mm, with reversible jaws (overlapping) - A2-6" **(C 570)**
- Universal 3-jaw chuck Ø 250 mm, with reversible jaws (overlapping) - A2-8" **(C 570)**
- Hydraulic chuck Ø 254 mm or Ø 315 mm serrated 1.5 x 60 mm - A2-8" **(C 670)**
- Universal 3-jaw chuck Ø 250 mm or Ø 315 mm, with reversible (overlapping) jaws - A2-8" **(C 670)**
- Air conditioning
- Auto shutdown feature
- Autotransformer
- Hydraulically-driven movable headstock
- Basic electrical installation
- Packaging
- External M-code interface
- Romi Manual Machine Package
- Status light indicator
- Steady Rest U-Type - Ø50 to Ø210 **(C 470)**
- Steady Rest Closed - Ø8 to Ø152 **(C 470/570)**
- Steady Rest Open - Ø8 to Ø80 **(C 470/570)**
- FollowRest - Ø12 to Ø50 **(C 470)**
- FollowRest - Ø15 to Ø80 **(C 570)**
- Steady Rest U-Type - Ø30 to Ø345 **(C 670)**
- Steady Rest Closed - Ø20 to Ø255 **(C 670)**
- Separate manuals
- Software options
- Foot switch for clamping device
- Foot switch for tailstock
- Wash gun
- 4-Jaws Independent Chuck D250 or D315 for A2-6 and D315 or D400 for A2-8 **(C 570)**
- 4-Jaws Independent Chuck D315 or D400 or D500 for A2-8 **(C 670)**
- Live center
- Gang tools **(C 470)**
- Rear tool holder **(C 470/570/670)**
- Quick change tool holder, 2 or 3 faces **(C 470)**
- Manual square turret **(C 470)**
- Quick change tool holder, 3 faces **(C 570/670)**
- 8 station disk type (horizontal) automatic turret **(C 570)**
- 8 station disk type (horizontal) automatic turret **(C 670)**
- 4 station square vertical automatic turret **(C 670)**
- 8 station disk type (horizontal) with Driven Tools **(C 670)**
- Bar puller
- Oil skimmer
- Hydraulic unit

# WORLDWIDE PRESENCE

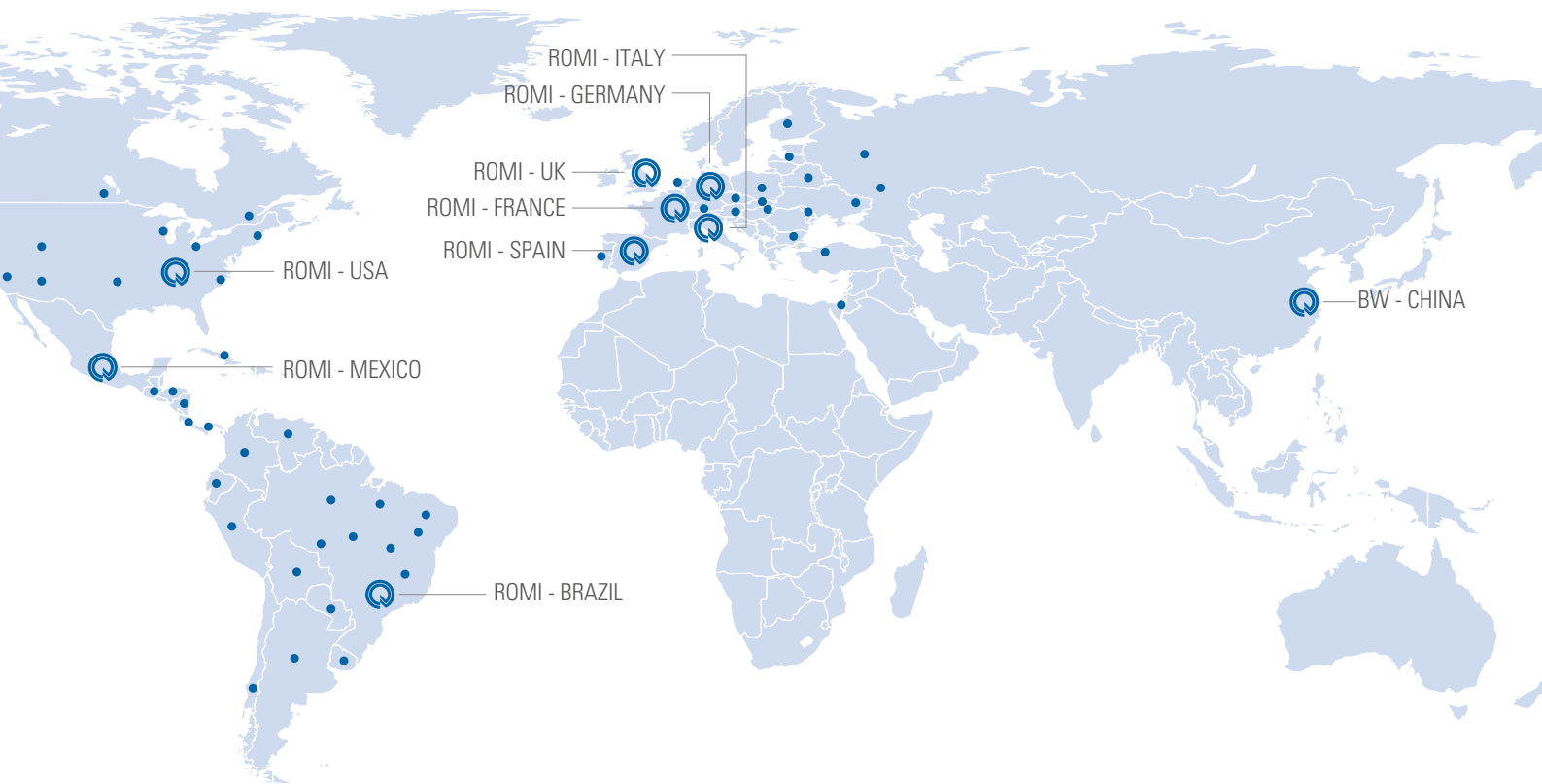

Brazil



United States



Germany



England



France



Spain



Italy



Mexico



Germany - BW



China - B+W



# ROMI

WWW.ROMI.COM

## ROMI S.A.

Rod. SP 304, Km 141,5  
Santa Bárbara d'Oeste SP  
13459 057 Brazil  
+55 (19) 3455 9000

## Latin America

+55 (19) 3455 9642  
export-mf@romi.com

## Burkhardt+Weber Shanghai

+86 21 6100-5568  
info@cn.burkhardt-weber.net

## Burkhardt+Weber

**Fertigungssysteme GmbH**  
Burkhardt+Weber-Strasse 57  
72760 Reutlingen, Germany  
+49 7121 315-0  
info@burkhardt-weber.de  
www.burkhardt-weber.de

## ROMI BW Machine Tools Ltd

1845 Airport Exchange Blvd  
Erlanger KY – 41018 USA  
+1 (859) 647 7566  
sales-usa@romi.com  
www.romiusa.com

## ROMI Europa GmbH

Burkhardt+Weber-Strasse 57  
72760 Reutlingen, Germany  
+49 7121 315-604  
info-eu@romi.com  
www.romi-europa.de

## ROMI France SAS

Parc de Genève, 240  
Rue Ferdinand Perrier 69800  
ST Priest  
+33 4 37 25 60 70  
infos@romifrance.fr  
www.romifrance.fr

## ROMI Machines UK Limited

Leigh Road  
Swift Valley Industrial Estate  
Rugby CV21 1DS  
+44 1788 544221  
sales@romiuk.com  
www.romiuk.com

## ROMI Maquinas España

C/ Telemática, 9 - Poligono  
Industrial La Ferreria - 08110  
Montcada I Reixac - Barcelona  
+34 93 719 4926  
info@romi.es  
www.romi.es

## ROMI en México

Condominio Parque Arista, Calle  
Gral. Mariano Arista 54, bodega 19  
Col. Argentina Poniente, Miguel Hidalgo  
C.O. 11230, CDMX, México  
+521 55 9154 5851  
ventasmx@romi.com  
www.romimexico.com

## ROMI Itàlia Srl

Via Morigi, 33 – 29020  
Gossolengo (PC) – Italy  
+39 0523 778 956  
direzione@romi.com  
www.romitalia.it



ISO 9001:2015  
Certificate No. 31120



ISO 14001:2015  
Certificate No. 70671



CE safety regulation compliance available only for the European Community or under request.  
Check availability and technical characteristics of the products to your country.

